

ZF 6HP19 / 6HP21

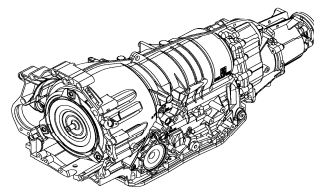

6HP19
6HP21

Automatic Transmission Spare Parts Catalog

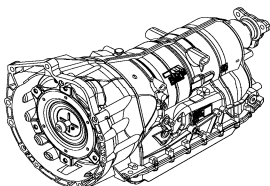
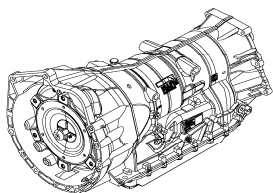

Warranty Information

Warranty coverage for ZF passenger car transmission spare parts and kits covers the first 12 months after installation in the vehicle, or 24 months after purchase from ZF Services.

Warranty of the product is limited to replacement or repair, if found to be defective in ZF material or workmanship, and specifically does not cover removal, reinstallation, or any costs incidental to the repair of the vehicle, or any kind of consequential damages.

All warranty and/or non-warranty returns must be approved.

Disclaimer

The specifications and information shown in this catalog have been compiled from accepted and reliable sources and is believed to be accurate at the time of publication. While ZF Services believes this information is correct, no guarantee or warranty is made as to the accuracy of the information and ZF Services cannot and does not accept or assume any responsibilities for errors, omissions, or consequential harm or damages. Replacement parts should not be used when they do not appear to fit. ZF Services disclaims all liability and responsibility for any harm resulting from any such modifications.

Copyright

Printed in USA - Copyright © 2008 ZF Services

No part of this publication may be reproduced, stored in a retrieval system, or transmitted, in any form or by any means, electronic, mechanical, photocopying, recording, or otherwise, without prior written permission of ZF Services.

Distributed By

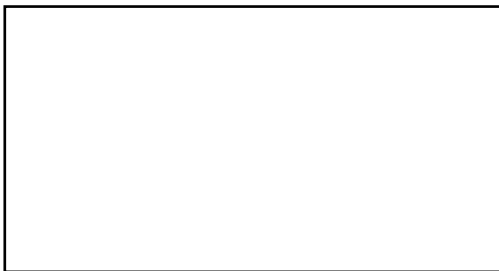



Table of Contents

6HP19 / 6HP21

Technical Information

Torque, Gear Ratio & Weight_____	2
Oil Capacity_____	2
6HP19 / 6HP21 Lubricants_____	2
6HP19 / 6HP21 Technical Literature_____	2
6HP19 / 6HP21 General Transmission Oil Filling Procedure_____	3 - 5
How To Use This Catalog_____	6
Type Plate Information_____	7

6HP19 1071 010 XXX / 6HP21 1071 030 XXX**Spare Parts**

Gearbox Housing Group_____	8
Torque Converter Group_____	9
Oil Supply Group_____	10
Front Planetary Group_____	11
Rear Planetary Group_____	12
Coupling A Group_____	13
Coupling B Group_____	14
Coupling C Group_____	15
Coupling D Group_____	16
Coupling E Group_____	17
Output Group_____	18
Filter Group_____	19
Mechatronic Group_____	20
Gear Shift System E-Shift Group_____	21
Gear Shift System M-Shift Group_____	22
Parking Lock Group_____	23

Selective Shims, Snap Rings & Kits Content

Selective Shims_____	24
Selective Snap Rings_____	25 - 26
Kits Content_____	27 - 29



Technical Information

Torque, Gear Ratio & Weight

Input Torque	1 Gear	2 Gear	3 Gear	4 Gear	5 Gear	6 Gear	Rev Gear	Drive	Weight (incl. oil)
258 ftlbs to 295 ftlbs (model specific)	4.17	2.34	1.52	1.14	0.87	0.69	3.40	RWD	~165 lbs.

Oil Capacity

9 liters (9.51 Quarts) + 0.5 liter for cooling system

6HP19 / 6HP21 Lubricants

Amount	ZF Part #	Oil Grade
209 Liter Drum	S671 090 252	ZF LifeGuardFluid 6
20 Liter Canister	S671 090 253	ZF LifeGuardFluid 6
1 Liter Bottle	S671 090 255	ZF LifeGuardFluid 6

Note: ZF recommends the use of LifeGuardFluid 6 for optimal performance.

6HP19 / 6HP21 Technical Literature

Language	ZF Part #	Description
English	1071 766 701	6HP19 REPAIR MANUAL (CD)
English	1071 751 701	6HP21 REPAIR MANUAL (CD)
English	1068 766 701	6HP19 / 6HP21 FUNCTIONAL DESCRIPTION - BMW (CD)
English	1068 766 704	6HP19 / 6HP21 FUNCTIONAL DESCRIPTION - AUDI (CD)

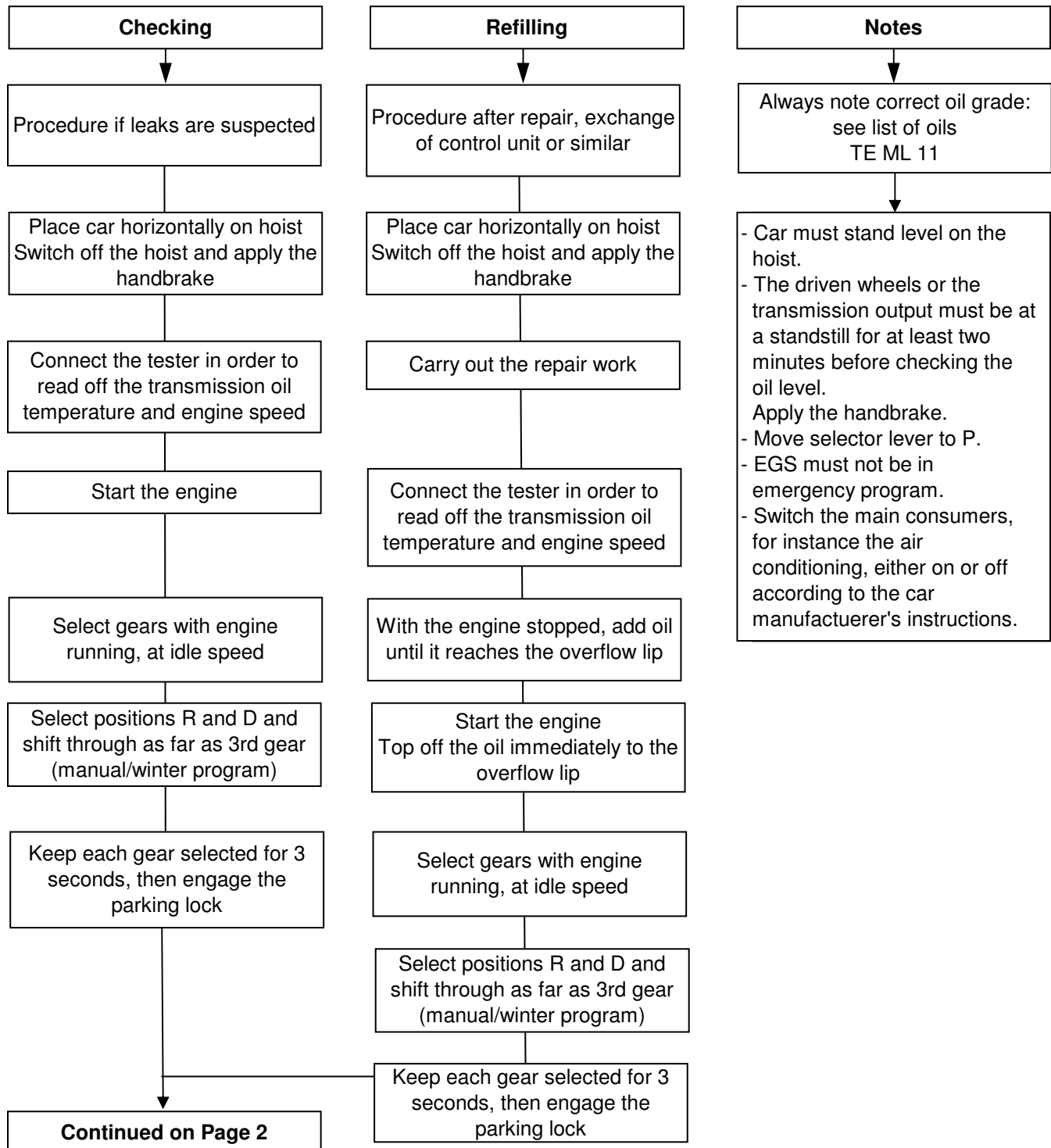

6HP19 / 6HP21 General Transmission Oil Filling Procedure

**Adding oil to 6HP19 / 6HP21 automatic transmission
- general - up to overflow at 40 °C**

For a distributor in your area call ZF at 1-800-451-2595 or visit our website at www.zf.com/na.



6HP19 / 6HP21 General Transmission Oil Filling Procedure (continued)

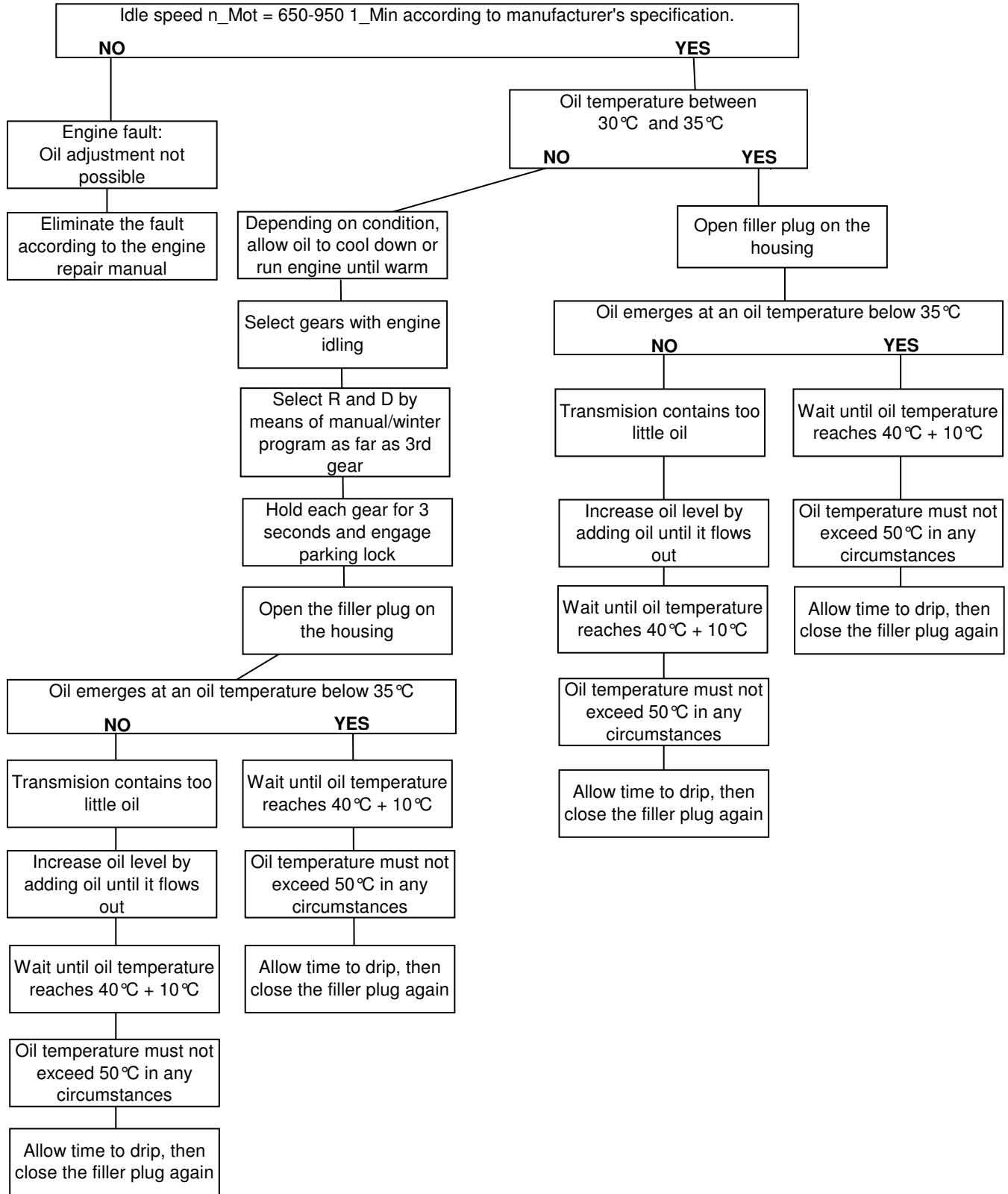



6HP19 / 6HP21 General Transmission Oil Filling Procedure (continued)

Oil service 6HP19 / 6HP21

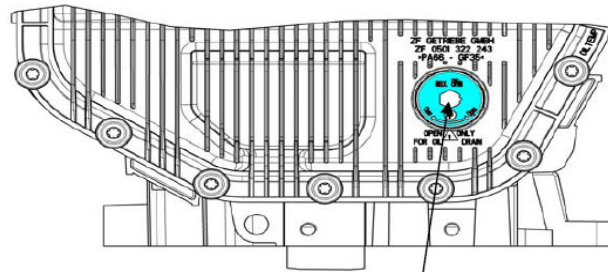
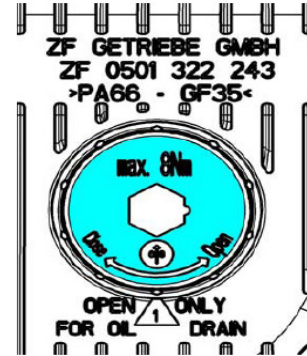
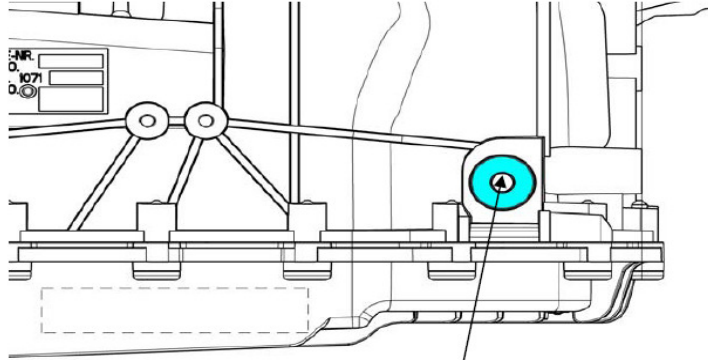

Oil filler screw and oil level screw	M18X1.5
Internal hexagon	8 mm
Tightening torque	35 Nm ± 3.5 Nm

Oil drain plug	M16X1.5
Internal hexagon	8 mm
Tightening torque	8 Nm



How To Use This Catalog

Table of Contents

Each transmission group of this catalog is listed in the table of contents. This spare parts catalog includes only transmission specification numbers for North American applications.

Technical Information

All technical information is specific to the transmission models that are referenced in this catalog. Weight and oil capacity information are only approximate and may vary by actual transmission specification. For any technical inquiry, please contact your preferred ZF passenger car transmission distributor for assistance. For a list of technical literature available from ZF or for answers to frequently asked questions about ZF transmissions visit us at www.zf.com/na.

Spare Parts

Each transmission is divide into groups (e.g. gearbox housing group). The position number (**Position #**) is used to identify the location of each spare part in the transmission. A position number like 01.010 is either a spare part or an assembly. A position number like 01.010/110 is a subcomponent of an assembly. Please contact your preferred ZF passenger car transmission distributor about availability of assemblies and subcomponents.

Contact ZF for the most updated part number (for example: 6HP19 1071 040 XXX). Please, have the position number and model number prepared when you call. Thank you.

Use our toll free Service-Hotline: 1-800-451-2595.

The description (**Description**) identifies the spare part.

The quantity (**Quantity**) is the amount of spare parts included in one transmission model for a certain position number. The quantity may vary depending on the transmission specification and certain spare parts may be used in multiple positions in the transmission.

The notes column (**Notes**) gives more information about the spare part (e.g. included in a kit).

Example

OIL SUPPLY GROUP

Position #	Description	Quantity	Notes
10.010	PUMP	1	
10.010/150	NEEDLE SLEEVE	1	
10.090	SHIM	1	Selective shim; see page 24.

Selective Shims, Snap Rings & Kits Content

Each list for selective shims or snap rings is listed in this section of the catalog. Please measure the clearance according to the repair manual and select the required spare part from the table.

The kits content section shows all available kits for the transmission models that are referenced in this catalog, including the content of each kit.

Mechatronic and Valve Body are only available as complete Service-Mechatronic.

For a distributor in your area call ZF at 1-800-451-2595 or visit our website at www.zf.com/na.



Type Plate Information

The type plate is located on the main housing of the transmission. Please refer to the ZF transmission specification # when searching for spare parts and kits in this catalog.

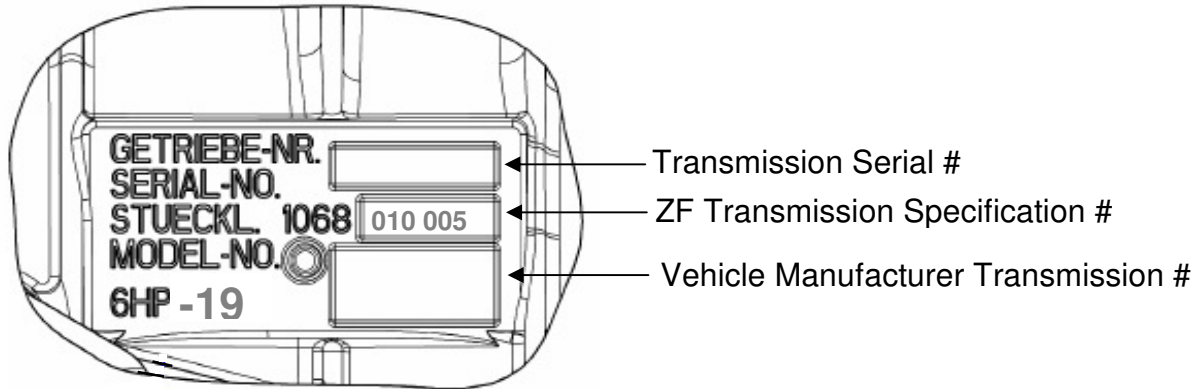



6HP19 1071 010 XXX / 6HP21 1071 030 XXX

GEARBOX HOUSING GROUP

Position #	Description	Quantity	Notes
01.010	GEARBOX HOUSING	1	
01.030	SEALING SLEEVE	2	Included in overhaul kit; see page 29.
01.040	SEALING SLEEVE	1	Included in overhaul kit; see page 29.
01.050	SEALING SLEEVE	1	Included in overhaul kit; see page 29.
01.070	BREATHER TUBE	1	
01.080	BREATHER COVER	1	
01.100	SCREW PLUG	1	M10X1.0; Included in overhaul kit; see page 29.
01.110	CYLINDRICAL PIN	1	
01.140	SCREW PLUG	1	M18X1.5; Included in overhaul kit; see page 29.
01.220	SHIPPING PLUG	1	

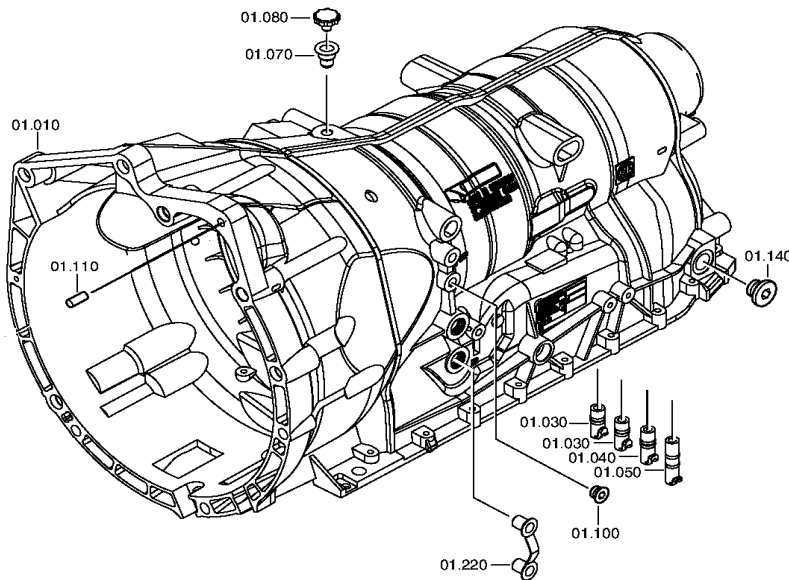



TORQUE CONVERTER GROUP

Position #	Description	Quantity	Notes
22.010	CONVERTER	1	
97.010	RETAINING CLIP	1	
97.020	BOLT + NUT	1	
97.030	CAP SCREW	1	

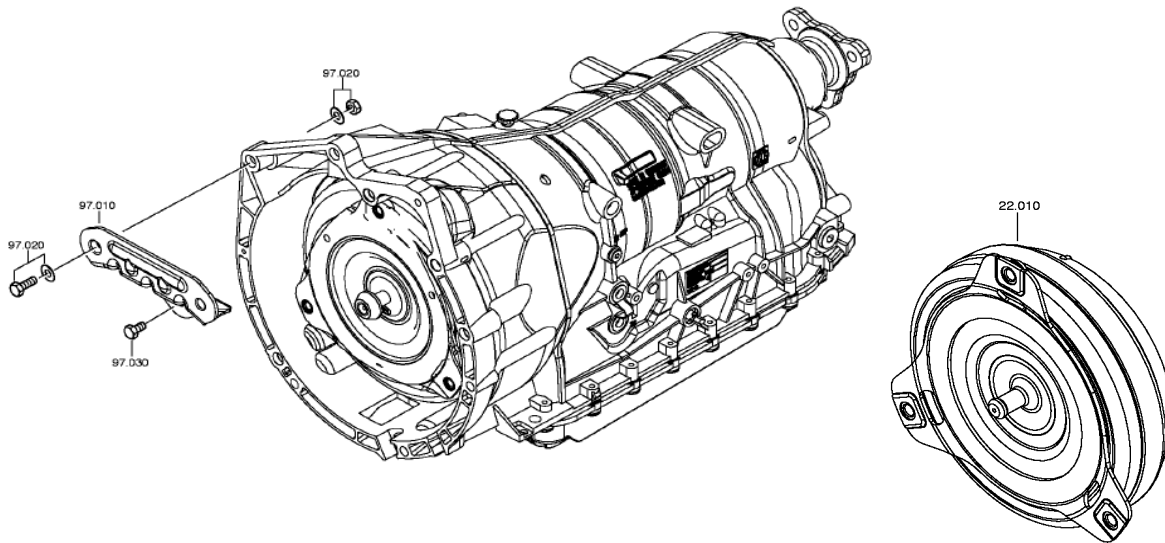



OIL SUPPLY GROUP

Position #	Description	Quantity	Notes
10.010	PUMP ASSEMBLY	1	
10.010/150	NEEDLE SLEEVE	1	
10.010/160	SNAP RING	1	
10.010/170	SHAFT SEAL	1	Included in overhaul kit; see page 29.
10.020	ROUND SEALING RING	1	Included in overhaul kit; see page 29.
10.040	INTERMEDIATE PLATE ASSEMBLY	1	
10.040/110	INTERMEDIATE PLATE	1	
10.040/130	CENTERING PLATE	1	
10.040/150	COUNTER SPRING	6	
10.040/160	PISTON RING	1	Included in overhaul kit; see page 29.
10.040/170	PISTON RING	1	Included in overhaul kit; see page 29.
10.050	COUNTER SPRING	11	M6X52
10.070	ROUND SEALING RING	1	Included in overhaul kit; see page 29.
10.080	TORX SCREW	11	M6X8; Included in overhaul kit; see page 29.
10.090	SHIM	1	Selective shim; see page 24.

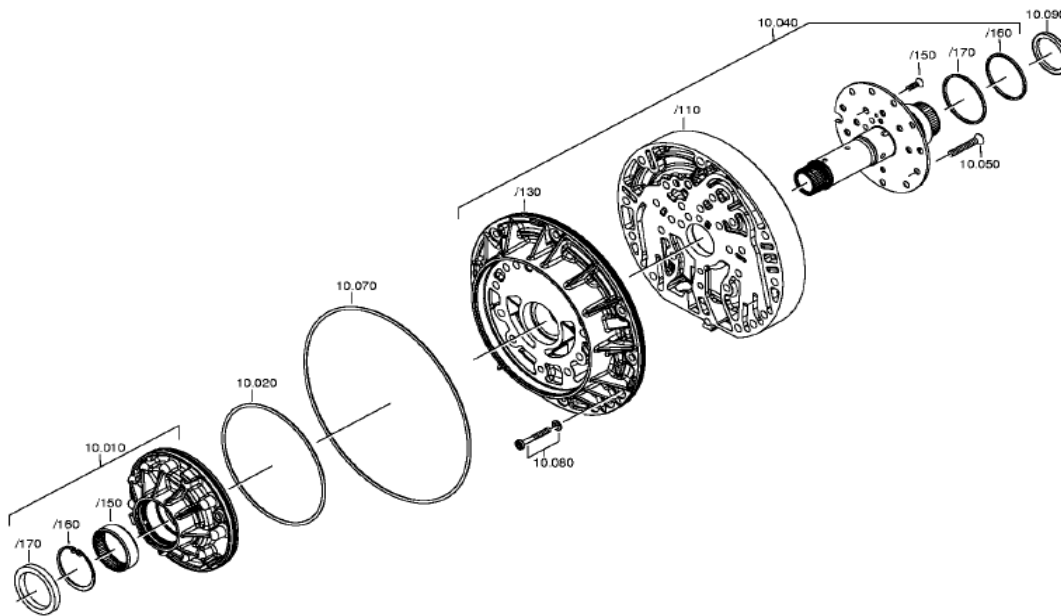



FRONT PLANETARY DRIVE GROUP

Position #	Description	Quantity	Notes
32.010	PLANET CARRIER ASSEMBLY	1	
32.010/180	ANGLE DISC	1	
32.010/190	AXIAL NEEDLE BEARING	1	
32.010/200	ANGLE DISC	1	
32.010/210	SUN GEAR	1	
32.100	AXIAL NEEDLE BEARING	1	
32.200	OIL COLLECTING PLATE	1	

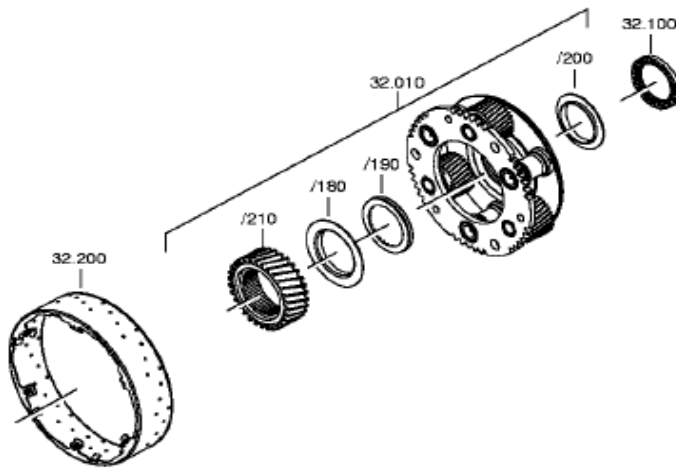



REAR PLANETARY DRIVE GROUP

Position #	Description	Quantity	Notes
42.010	PLANET CARRIER ASSEMBLY	1	
42.010/260	AXIAL NEEDLE BEARING	1	
42.010/280	AXIAL NEEDLE BEARING	1	
42.010/290	AXIAL WASHER	1	
42.170	RING GEAR	1	
42.180	SNAP RING	1	
42.190	OUTPUT SHAFT	1	
42.210	AXIAL NEEDLE BEARING	1	
42.260	STOP RING	1	
42.280	ANGLE DISC	1	
42.290	AXIAL NEEDLE BEARING	1	

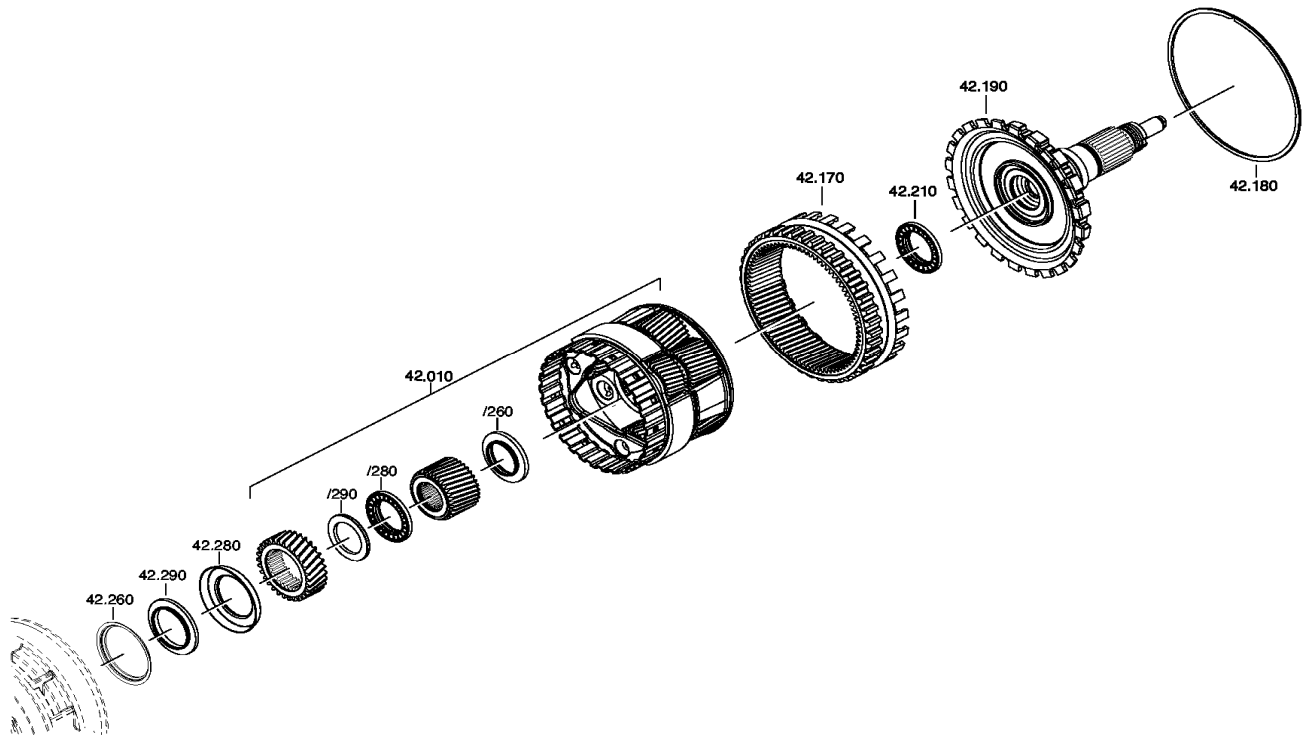



COUPLING A GROUP

Position #	Description	Quantity	Notes
70.010	CYLINDER ASSEMBLY	1	
70.010/110	CYLINDER	1	
70.010/120	PISTON	1	
70.010/130	PROFILED SEALING RING	1	Included in overhaul kit; see page 29.
70.010/140	ROUND SEALING RING	1	Included in overhaul kit; see page 29.
70.010/150	CUP SPRING	1	
70.010/160	OIL DAM	1	
70.010/170	PROFILED SEALING RING	1	Included in overhaul kit; see page 29.
70.010/180	K-RING	1	
70.130	UNDULATING SPRING	1	
70.140	STEEL PLATE	5	3.00 mm; Included in steel kit; see page 28.
70.150	FRICTION PLATE	4	Included in friction kit; see page 27.
70.170	SNAP RING	1	Selective snap ring; see page 25.

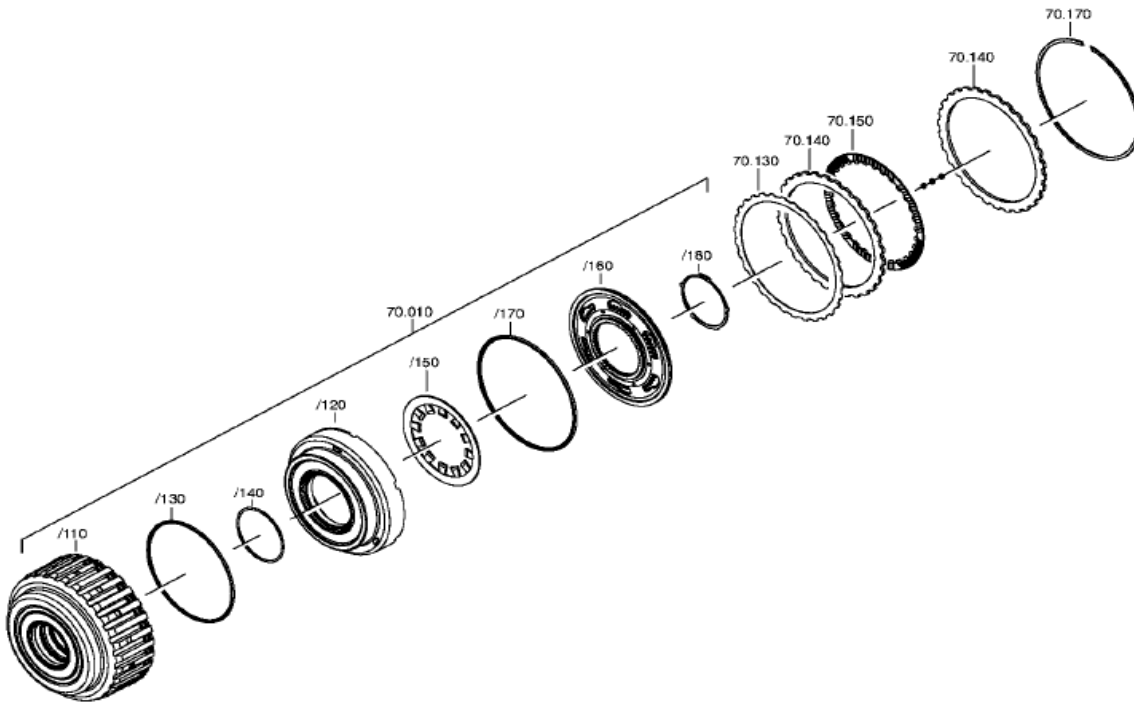



COUPLING B GROUP

Position #	Description	Quantity	Notes
72.010	SUN GEAR SHAFT	1	
72.020	PISTON	1	
72.050	ROUND SEALING RING	1	Included in overhaul kit; see page 29.
72.060	ROUND SEALING RING	1	Included in overhaul kit; see page 29.
72.070	CUP SPRING	1	
72.080	OIL DAM	1	
72.100	ROUND SEALING RING	1	Included in overhaul kit; see page 29.
72.110	SPLIT RING	1	
72.130	UNDULATING SPRING	1	
72.140	END PLATE	1	3.00 mm; Included in steel kit; see page 28.
72.144	STEEL PLATE	5	2.40 mm; Included in steel kit; see page 28.
72.150	FRICTION PLATE	5	Included in friction kit; see page 27.
72.170	SNAP RING	1	Selective snap ring; see page 25.
72.200	PISTON RING	2	Included in overhaul kit; see page 29.
72.210	AXIAL NEEDLE BEARING	1	

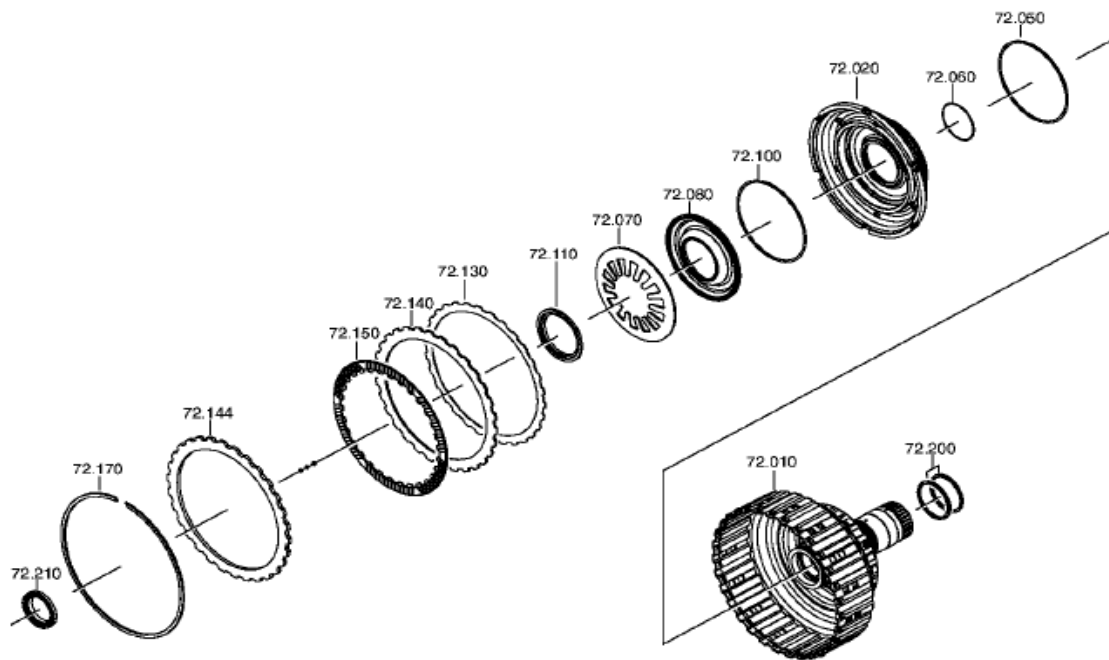



COUPLING C GROUP

Position #	Description	Quantity	Notes
75.010	CYLINDER	1	
75.010/140	FITTING KEY	2	
75.030	PISTON	1	
75.040	ROUND SEALING RING	1	Included in overhaul kit; see page 29.
75.050	ROUND SEALING RING	1	Included in overhaul kit; see page 29.
75.070	CUP SPRING	1	
75.080	SPLIT RING	1	
75.100	UNDULATING SPRING	1	
75.120	FRICTION PLATE	4	Included in friction kit; see page 27.
75.140	STEEL PLATE	4	2.50 mm; Included in steel kit; see page 28.
75.150	END PLATE	1	3.50 mm; Included in steel kit; see page 28.
75.180	SNAP RING	1	Selective snap ring; see page 25.

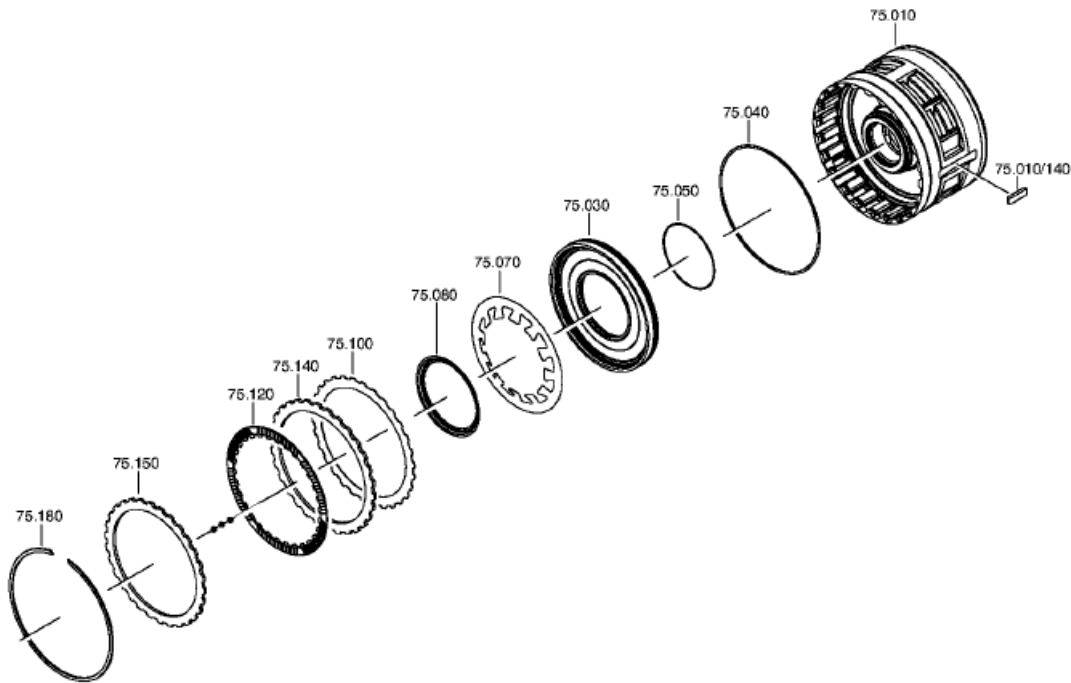

For a distributor in your area call ZF at 1-800-451-2595 or visit our website at www.zf.com/na.



COUPLING D GROUP

Position #	Description	Quantity	Notes
73.010	PISTON	1	
73.020	ROUND SEALING RING	1	Included in overhaul kit; see page 29.
73.030	ROUND SEALING RING	1	Included in overhaul kit; see page 29.
73.060	OIL DAM	1	
73.070	ROUND SEALING RING	1	Included in overhaul kit; see page 29.
73.080	ROUND SEALING RING	1	Included in overhaul kit; see page 29.
73.120	CUP SPRING	1	
73.130	SUPPORT SHIM	1	
73.136	SNAP RING	1	2.00 mm
73.150	UNDULATING SPRING	1	
73.160	STEEL PLATE	5	1.80 mm; Included in steel kit; see page 28.
73.170	FRICTION PLATE	5	Included in friction kit; see page 27.
73.180	END PLATE	1	3.50 mm; Included in steel kit; see page 28.
73.190	SNAP RING	1	Selective snap ring; see page 26.
73.210	SNAP RING	1	
73.290	ANGLE DISC	1	
73.300	AXIAL NEEDLE BEARING	1	

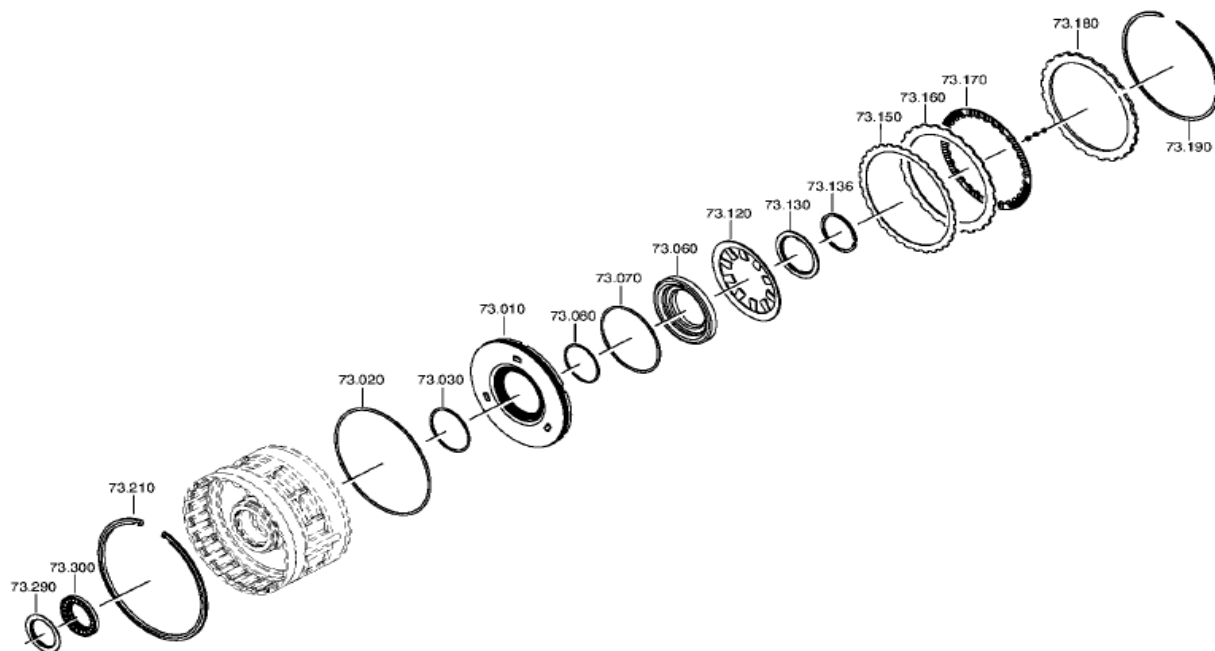

For a distributor in your area call ZF at 1-800-451-2595 or visit our website at www.zf.com/na.



COUPLING E GROUP

Position #	Description	Quantity	Notes
71.010	INPUT SHAFT	1	
71.020	PISTON	1	
71.030	ROUND SEALING RING	1	Included in overhaul kit; see page 29.
71.040	ROUND SEALING RING	1	Included in overhaul kit; see page 29.
71.060	CUP SPRING	1	
71.080	OIL DAM	1	
71.090	ROUND SEALING RING	1	
71.094	FIXING PLATE	1	
71.100	SNAP RING	1	
71.140	UNDULATING SPRING	1	
71.150	STEEL PLATE	4	2.10 mm; Included in steel kit; see page 28.
71.160	FRICTION PLATE	4	Included in friction kit; see page 27.
71.170	END PLATE	1	3.50 mm; Included in steel kit; see page 28.
71.180	SNAP RING	1	Selective snap ring; see page 26.
71.190	SEALING RING	3	Included in overhaul kit; see page 29.
71.220	ROUND SEALING RING	1	Included in overhaul kit; see page 29.
71.240	SUN GEAR SHAFT	1	
71.260	AXIAL NEEDLE BEARING	1	
71.280	INTERMEDIATE SHAFT	1	
71.290	AXIAL NEEDLE BEARING	1	
71.300	DISC CARRIER	1	
71.310	SNAP RING	1	

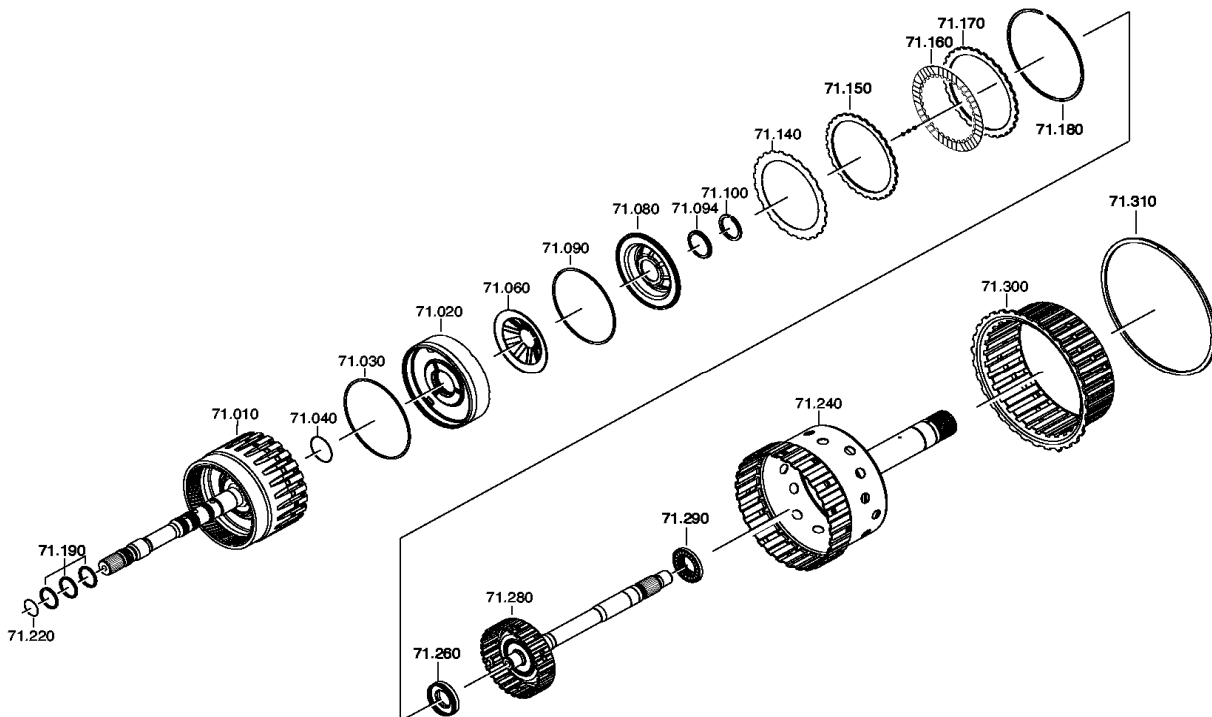

For a distributor in your area call ZF at 1-800-451-2595 or visit our website at www.zf.com/na.



OUTPUT GROUP

Position #	Description	Quantity	Notes
14.020	NEEDLE SLEEVE	1	
14.040	SNAP RING	1	
14.050	SHIM	1	Selective shim; see page 24.
14.070	BALL BEARING	1	
14.090	SNAP RING	1	
14.110	SHAFT SEAL	1	Included in overhaul kit; see page 29.
14.130	SHIM	1	1.00 mm
14.140	OUTPUT FLANGE	1	
14.150	SHAFT SEAL	1	Included in overhaul kit; see page 29.
14.160	COLLAR NUT	1	M27X1.5; Do not reuse.

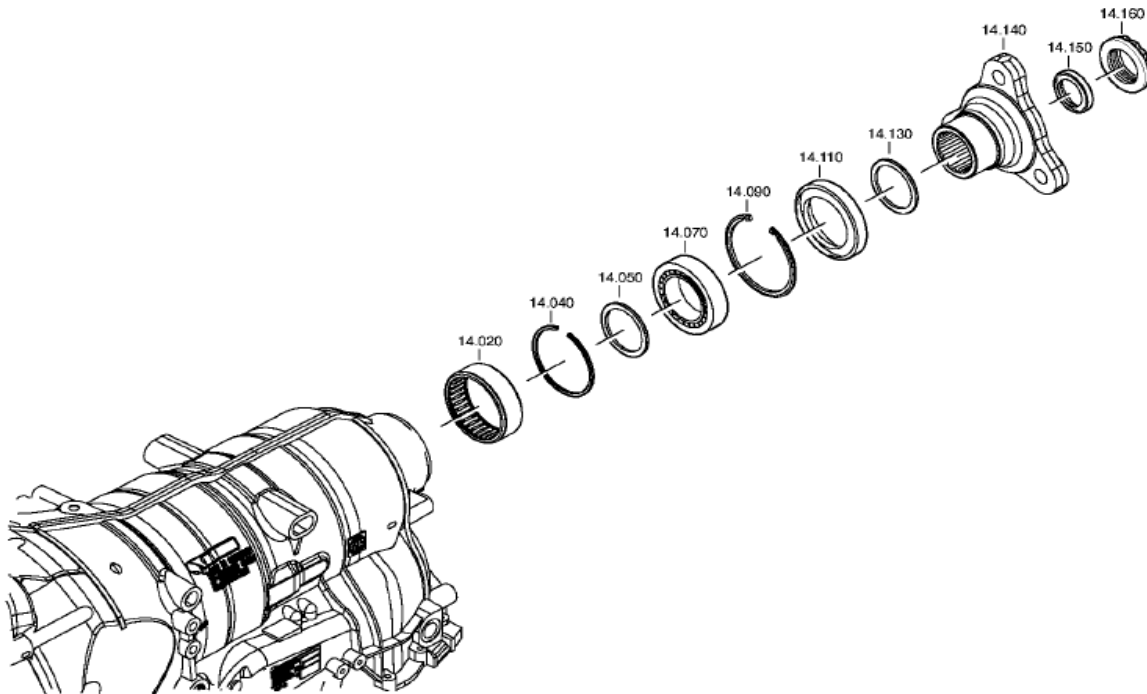



FILTER GROUP

Position #	Description	Quantity	Notes
03.010	FILTER KIT	1	Included in filter kit; see page 27.
03.010/010	GASKET	1	Included in overhaul kit; see page 29.
03.010/020	ROUND SEALING RING	1	Included in overhaul kit; see page 29.
03.010/030	SCREW PLUG	1	Included in overhaul kit; see page 29.
03.020	TORX SCREW	24	M6X28.5

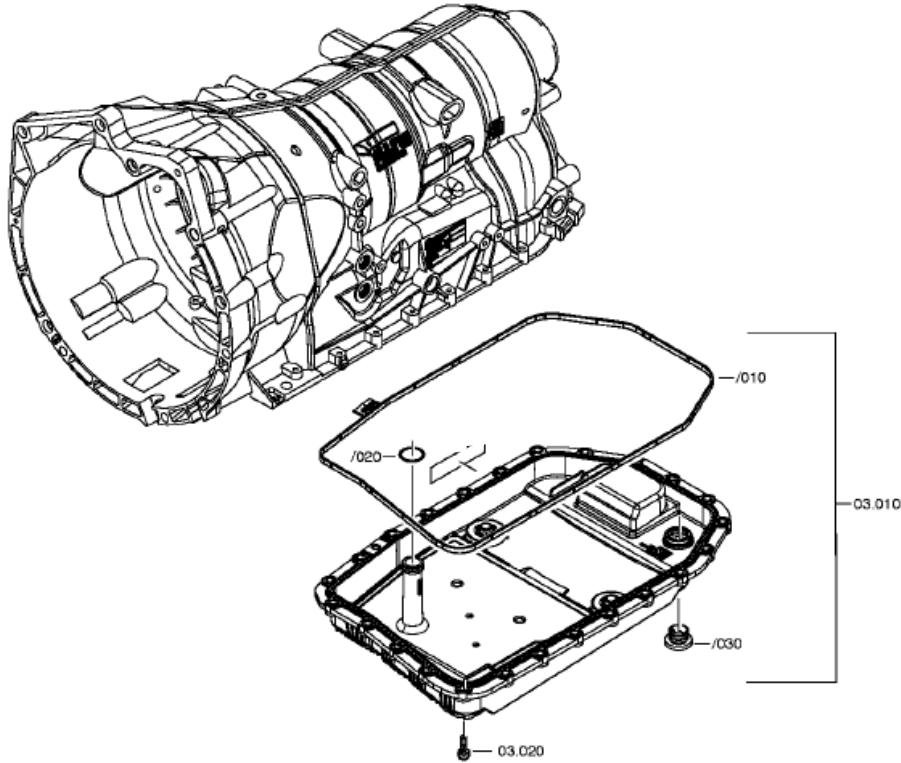



MECHATRONIC GROUP

Position #	Description	Quantity	Notes
27.460	GASKET	2	Included in overhaul kit; see page 29.
27.520	GUIDE SLEEVE	1	Included in overhaul kit; see page 29.
27.700	CAP	1	
27.730	CAPACITOR	1	
27.740	CLAMP	1	
N/A	MECHATRONIC	1	Only complete Service-Mechatronics are available.

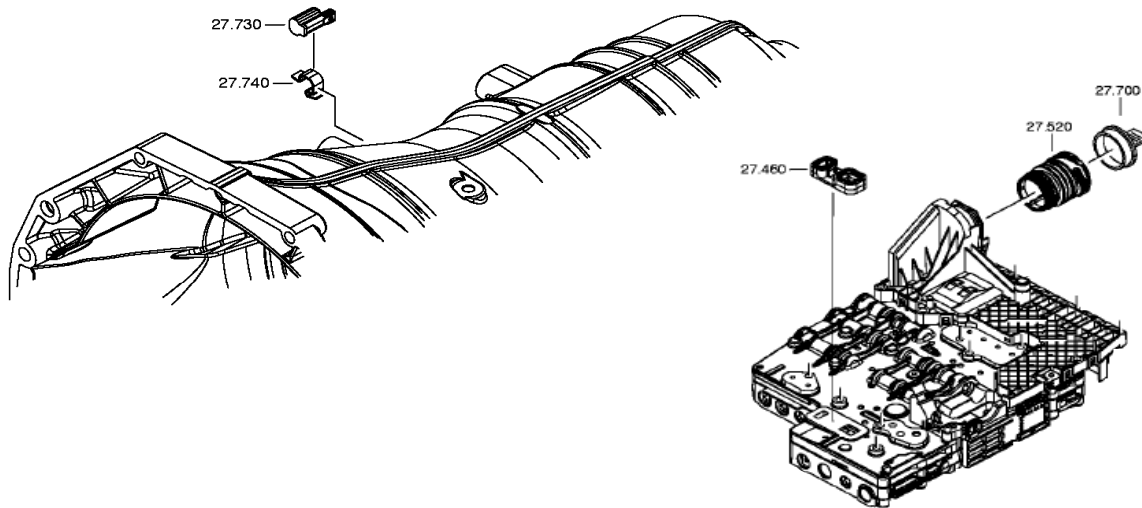

CAUTION!

Only complete Service-Mechatronics are available.

Contact your local ZF Parts distributor for more information.



GEARSHIFT SYSTEM E-SHIFT GROUP

Position #	Description	Quantity	Notes
06.010	SHAFT SEAL	1	Included in overhaul kit; see page 29.
06.030	SELECTOR SHAFT	1	
06.050	PARKING LOCK DISC	1	
06.060	CLAMPING SLEEVE	1	
06.070	PIPE	1	
06.090	LEG SPRING	1	
06.150	LEVER	1	
06.170	ANGLE BRACKET	1	
06.170/110	ANGLE BRACKET	1	
06.170/120	ANGLE BRACKET	1	
06.170/130	HEXAGON NUT	1	
06.190	HEXAGON NUT	1	
06.210	CAP SCREW	2	M16X14

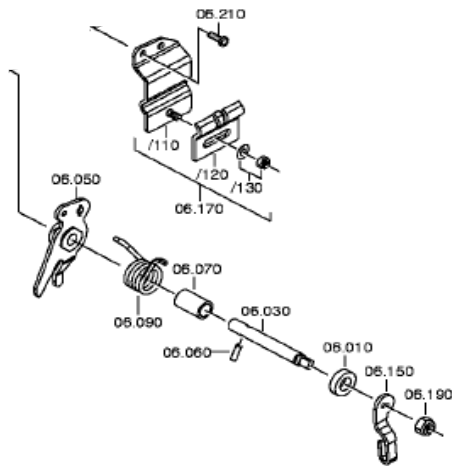



GEARSHIFT SYSTEM M-SHIFT GROUP

Position #	Description	Quantity	Notes
06.010	SHAFT SEAL	2	10X18X5; Included in overhaul kit; see page 29.
06.030	SELECTOR SHAFT	1	
06.050	ROOSTER COMB	1	
06.060	CLAMPING SLEEVE	1	
06.070	PIPE	1	22.50 mm
06.094	DETENT SPRING	1	
06.100	TORX SCREW	2	M6X13

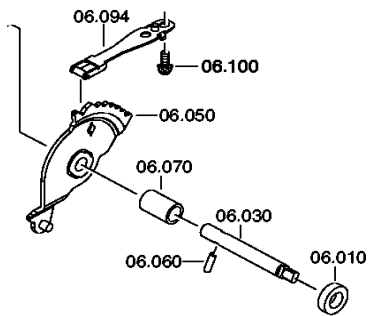



PARKING LOCK GROUP

Position #	Description	Quantity	Notes
24.010	PIN	1	
24.020	SCREW PLUG	1	M14X1.5; Included in overhaul kit; see page 29.
24.040	PAWL	1	
24.060	LEG SPRING	1	
24.080	CONNECTING BAR	1	
24.110	GUIDING PLATE	1	
24.120	TORX SCREW	3	M6X20

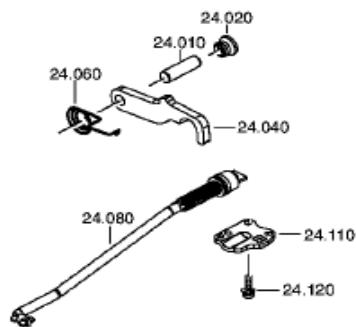

6HP19 1071 010 XXX / 6HP21 1071 030 XXX SELECTIVE SHIMS
6HP19 / 6HP21 SELECTIVE SHIM

Position #	Select. Parts	Description	Quantity		Notes
10.090	OIL SUPPLY SHIM				
	0730 009 823	SHIM	1	5.00	
	0730 009 529	SHIM	1	4.80	
	0730 009 528	SHIM	1	4.60	
	0730 009 527	SHIM	1	4.40	
	0730 009 526	SHIM	1	4.20	
	0730 009 525	SHIM	1	4.00	
	0730 009 524	SHIM	1	3.80	
	0730 009 523	SHIM	1	3.60	
	0730 009 522	SHIM	1	3.40	
	0730 009 521	SHIM	1	3.20	
	0730 009 520	SHIM	1	3.00	
	0730 009 519	SHIM	1	2.80	
	0730 009 518	SHIM	1	2.60	

6HP19 / 6HP21 SELECTIVE SHIM

Position #	Select. Parts	Description	Quantity		Notes
14.050	OUTPUT SHIM				
	0730 112 642	SHIM	1	1.00	
	0730 112 643	SHIM	1	1.20	
	0730 112 644	SHIM	1	1.40	
	0730 112 645	SHIM	1	1.60	
	0730 112 646	SHIM	1	1.80	
	0730 112 647	SHIM	1	2.00	
	0730 112 648	SHIM	1	2.20	
	0730 112 649	SHIM	1	2.40	
	0730 112 650	SHIM	1	2.60	
	0730 112 651	SHIM	1	2.80	
	0730 112 652	SHIM	1	3.00	
	0730 112 653	SHIM	1	3.20	



6HP19 1071 010 XXX / 6HP21 1071 030 XXX

SELECTIVE SNAP RINGS

6HP19 / 6HP21 SELECTIVE SNAP RING

Position #	Select. Parts	Description	Quantity		Notes
70.170	COUPLING A SNAP RING				
	0730 513 834	SNAP RING	1	3.20	
	0730 513 833	SNAP RING	1	3.00	
	0730 513 832	SNAP RING	1	2.80	
	0730 513 831	SNAP RING	1	2.60	
	0730 513 830	SNAP RING	1	2.40	
	0730 513 829	SNAP RING	1	2.20	
	0730 513 828	SNAP RING	1	2.00	
	0730 513 827	SNAP RING	1	1.80	

6HP19 / 6HP21 SELECTIVE SNAP RING

Position #	Select. Parts	Description	Quantity		Notes
72.170	COUPLING B SNAP RING				
	0730 513 834	SNAP RING	1	3.20	
	0730 513 833	SNAP RING	1	3.00	
	0730 513 832	SNAP RING	1	2.80	
	0730 513 831	SNAP RING	1	2.60	
	0730 513 830	SNAP RING	1	2.40	
	0730 513 829	SNAP RING	1	2.20	
	0730 513 828	SNAP RING	1	2.00	
	0730 513 827	SNAP RING	1	1.80	

6HP19 / 6HP21 SELECTIVE SNAP RING

Position #	Select. Parts	Description	Quantity		Notes
75.180	COUPLING C SNAP RING				
	0730 513 845	SNAP RING	1	3.60	
	0730 513 844	SNAP RING	1	3.40	
	0730 513 843	SNAP RING	1	3.20	
	0730 513 842	SNAP RING	1	3.00	
	0730 513 841	SNAP RING	1	2.80	
	0730 513 840	SNAP RING	1	2.60	
	0730 513 839	SNAP RING	1	2.40	
	0730 513 838	SNAP RING	1	2.20	
	0730 513 837	SNAP RING	1	2.00	
	0730 513 836	SNAP RING	1	1.80	



6HP19 1071 010 XXX / 6HP21 1071 030 XXX

SELECTIVE SNAP RINGS

6HP19 / 6HP21 SELECTIVE SNAP RING

Position #	Select. Parts	Description	Quantity	Notes
73.190	COUPLING D SNAP RING			
	0730 513 845	SNAP RING	1	3.60
	0730 513 844	SNAP RING	1	3.40
	0730 513 843	SNAP RING	1	3.20
	0730 513 842	SNAP RING	1	3.00
	0730 513 841	SNAP RING	1	2.80
	0730 513 840	SNAP RING	1	2.60
	0730 513 839	SNAP RING	1	2.40
	0730 513 838	SNAP RING	1	2.20
	0730 513 837	SNAP RING	1	2.00
0730 513 836	SNAP RING	1	1.80	

6HP19 / 6HP21 SELECTIVE SNAP RING

Position #	Select. Parts	Description	Quantity	Notes
71.180	COUPLING E SNAP RING			
	0730 513 853	SNAP RING	1	3.20
	0730 513 852	SNAP RING	1	3.00
	0730 513 851	SNAP RING	1	2.80
	0730 513 850	SNAP RING	1	2.60
	0730 513 849	SNAP RING	1	2.40
	0730 513 848	SNAP RING	1	2.20
	0730 513 847	SNAP RING	1	2.00
0730 513 943	SNAP RING	1	1.80	



Kits Content

6HP19 / 6HP21 Kits Content

6HP19 Filter Kit (Plastic Oil Pan) – 1071 298 009

Position #	ZF Part #	Description	Quantity	Where used (1071 ____)	Notes
03.010	1071 298 009	Plastic Oil Pan incl.	1	All	
		Filter	1	All	
		Gasket	1	All	
		Round Sealing Ring	1	All	

6HP19 Friction Kit – 1071 298 013

Position #	ZF Part #	Description	Quantity	Where used (1071 ____)	Notes
70.150	1071 272 005	Friction Plate A	4	See Chart 013 Below	
71.160	1071 271 033	Friction Plate E	6	See Chart 013 Below	
72.150	1071 272 004	Friction Plate B	6	See Chart 013 Below	
73.170	1071 273 003	Friction Plate D	5	See Chart 013 Below	
75.120	1071 275 005	Friction Plate C	4	See Chart 013 Below	

Chart 013 Friction kit applications

6HP19**1071 010**

005 to 033

6HP21 Friction Kit – 1071 298 014

Position #	ZF Part #	Description	Quantity	Where used (1071 ____)	Notes
70.150	1071 272 005	Friction Plate A	4	See Chart 014 Below	
71.160	1071 271 082	Friction Plate E	6	See Chart 014 Below	
72.150	1071 272 004	Friction Plate B	6	See Chart 014 Below	
73.170	1071 273 003	Friction Plate D	5	See Chart 014 Below	
75.120	1071 275 005	Friction Plate C	4	See Chart 014 Below	

Chart 014 Friction kit applications

6HP21**1071 030**

003 to 004

006

013 to 014

016 to 027

029 to 031

034 to 035

037 to 038



Kits Content

6HP19 / 6HP21 Kits Content

6HP19 / 6HP21 Steel Kit – 1071 298 011

Position #	ZF Part #	Description	Quantity	Where used (1071 ____)	Notes
70.140	1071 372 010	Steel Plate A	5	See Chart 011 Below	
71.150	1071 371 048	Steel Plate E	5	See Chart 011 Below	
71.170	1071 371 094	End Plate E	1	See Chart 011 Below	
72.144	1071 372 025	Steel Plate B	6	See Chart 011 Below	
72.140	1071 372 061	End Plate B	1	See Chart 011 Below	
73.160	1071 373 009	Steel Plate D	5	See Chart 011 Below	
73.180	1071 373 006	End Plate D	1	See Chart 011 Below	
75.140	1071 375 006	Steel Plate C	4	See Chart 011 Below	
75.150	1071 375 007	End Plate C	1	See Chart 011 Below	

Chart 011 Steel kit applications

6HP19 1071 010 ____	6HP21 1071 030 ____
005 to 033	004
	006
	013 to 014
	020 to 022
	025
	027
	029 to 030
	037

6HP21 Steel Kit – 1071 298 012

Position #	ZF Part #	Description	Quantity	Where used (1071 ____)	Notes
70.140	1071 372 010	Steel Plate A	5	See Chart 012 Below	
71.150	1071 371 052	Steel Plate E	6	See Chart 012 Below	
71.170	1071 371 093	End Plate E	1	See Chart 012 Below	
72.144	1071 372 025	Steel Plate B	6	See Chart 012 Below	
72.140	1071 372 061	End Plate B	1	See Chart 012 Below	
73.160	1071 373 009	Steel Plate D	5	See Chart 012 Below	
73.180	1071 373 006	End Plate D	1	See Chart 012 Below	
75.140	1071 375 006	Steel Plate C	4	See Chart 012 Below	
75.150	1071 375 007	End Plate C	1	See Chart 012 Below	

Chart 012 Steel kit applications

6HP21 1071 030 ____
003
016 to 019
023 to 024
026
031
034 to 035
038



Kits Content

6HP19 / 6HP21 Kits Content

6HP19 / 6HP21 Overhaul Kit – 1071 298 007

Position #	ZF Part #	Description	Quantity	Where used		Group
				1071 010 ___	1071 030 ___	
75.040	0734 313 007	Round Sealing Ring	1	1071 030 ___		Coupling C
75.040	0734 313 195	Round Sealing Ring	1	1071 010 ___		Coupling C
75.050	0734 313 222	Round Sealing Ring	1	All		Coupling C
73.020	0734 313 195	Round Sealing Ring	1	All		Coupling D
73.030	0734 313 221	Round Sealing Ring	1	All		Coupling D
73.070	0734 313 019	Round Sealing Ring	1	All		Coupling D
73.080	0734 313 030	Round Sealing Ring	1	All		Coupling D
70.010/170	0501 320 493	Profiled Seal Ring	1	All		Coupling A
70.010/140	0734 313 028	Round Sealing Ring	1	All		Coupling A
70.010/130	0501 320 492	Profiled Seal Ring	1	All		Coupling A
72.050	0734 313 027	Round Sealing Ring	1	All		Coupling B
72.060	0734 313 033	Round Sealing Ring	1	All		Coupling B
72.100	0734 313 027	Round Sealing Ring	2	All		Coupling B
72.200	0734 317 403	Piston Ring	2	All		Coupling B
71.030	0734 313 040	Round Sealing Ring	1	All		Coupling E
71.040	0734 313 193	Round Sealing Ring	1	All		Coupling E
71.090	0734 313 009	Round Sealing Ring	1	All		Coupling E
71.190	0734 317 387	Sealing Ring	3	All		Coupling E
71.220	0734 313 846	Round Sealing Ring	1	All		Coupling E
01.030	0501 319 279	Sealing Sleeve	2	All		Gearbox housing
01.040	0501 319 280	Sealing Sleeve	1	All		Gearbox housing
01.050	0501 319 281	Sealing Sleeve	1	All		Gearbox housing
01.100	0501 321 921	Screw Plug	1	All		Gearbox housing
01.140	0501 321 922	Screw Plug	1	All		Gearbox housing
06.010	0734 319 801	Shaft Seal	2	All		Gearshift system
14.110	0734 319 633	Shaft Seal	1	All		Output
24.020	0501 323 684	Screw Plug	1	All		Parking lock
27.460	0501 321 776	Gasket	2	All		Mechatronic
27.460	0501 321 777	Gasket	2	All		Mechatronic
27.520	0501 216 272	Guide Sleeve	1	All		Mechatronic
03.010/030	0501 318 960	Screw Plug	1	All		Filter
03.010/020	0501 319 012	Round Sealing Ring	1	All		Filter
03.010/010	0501 323 156	Gasket	1	All		Filter
10.010/170	0734 319 695	Shaft Seal	1	All		Oil supply
10.040/170	0734 401 295	Piston Ring	1	All		Oil supply
10.040/160	0734 401 291	Piston Ring	1	All		Oil supply
10.020	0734 313 083	Round Sealing Ring	1	All		Oil supply
10.070	0734 313 165	Round Sealing Ring	1	All		Oil supply
10.080	1071 210 052	Torx Screw	11	All		Oil supply
14.150	0734 310 418	Shaft Seal	1	All		Output
14.150	0750 111 470	Shaft Seal	1	All		Output

Kits may contain items not used in all applications

For a distributor in your area call ZF at 1-800-451-2595 or visit our website at www.zf.com/na.